

**Modular Cooking Range Line
 thermaline 85 - Electric Free-cooking
 Top on Warming Cabinet with
 Backsplash H=700**

ITEM # _____

MODEL # _____

NAME # _____

SIS # _____

AIA # _____



588709 (MBTIGBH4AO) Electric Free-Cooking Top, one-side operated with backsplash, on Warming Cabinet

Short Form Specification

Item No. _____

Unit constructed according to DIN 18860_2 with 20 mm drop nose top. Internal frame for heavy duty sturdiness in stainless steel. 2 mm top in 1.4301 (AISI 304). Flat surface construction, easily cleanable. THERMODUL connection system enables seamless worktop when units are connected and avoids soil penetrating. Smooth electrically-heated solid plate (400x740 mm) made of 20 mm thick steel with a wide rounded cleaning zone around the plate. Rapid plate heat up, continuously ready to use; maximum reachable surface temperature of 350°C. Stainless steel high splash guards on the rear and sides. Overheat protection switches off the supply in case of overheating. Standby function saves energy and quickly recovers maximum power. Metal knobs with embedded hygienic silicon "soft" grip enable easier handling and cleaning. 800 mm wide warming cabinet with 2 doors, constructed according to DIN 18860_2 with 70 mm recessed plinth. Internal frame for heavy duty sturdiness in stainless steel. 2 mm top in 1.4301 (AISI 304). Flat surface construction, easily cleanable. THERMODUL connection system enables seamless worktop when units are connected and avoids soil penetrating. Temperature in the cabinet can be set through thermostat, up to a maximum of 110 °C. Cabinet storage space accepts GN 1/1 containers. IPX5 water resistance certification.

Main Features

- Rapid heat up of the plate and continuously ready for use.
- Overheat protection: the temperature sensor switches off the supply in case of overheating.
- Wide rounded cleaning zone around the plates for easier cleaning.
- All major components may be easily accessed from the front.
- THERMODUL connection system creates a seamless work top when units are connected to each other thus avoiding soil penetrating vital components and facilitating the removal of units in case of replacement or service.
- Metal knobs with embedded hygienic "soft-touch" grip for easier handling and cleaning. The special design of the controls prevents infiltration of liquids or soil into vital components.
- Cooking plate and base joint profile guarantee against soil infiltration.
- Surface temperature up to 350°C
- Unit constructed according to DIN 18860_2 with 70 mm recessed plinth.
- For direct and indirect cooking.
- Temperature in the cupboard can be set through a thermostat to suit different requirements. The maximum temperature is 110°C.

Construction

- 2 mm top in 1.4301 (AISI 304).
- Flat surface construction with minimal hidden areas to easily clean all surfaces
- IPX5 water resistance certification.
- Storage space in the base of the appliance accepts GN1/1 containers.
- Unit constructed according to DIN 18860_2 with 20 mm drop nose top.
- Cooking surface is an electrically heated solid plate made from 20 mm thick stainless steel AISI 316 - DIN 1.4404.
- 2mm thick top in stainless steel AISI 304 - DIN 1.4301.
- Internal frame for heavy duty sturdiness in stainless steel.

Sustainability

- Standby function for energy saving and fast recovery of maximum power.



APPROVAL: _____

Optional Accessories

- Connecting rail kit for appliances with backsplash, 850mm PNC 912498
- Portioning shelf, 800mm width PNC 912526
- Portioning shelf, 800mm width PNC 912556
- Folding shelf, 300x850mm PNC 912579
- Folding shelf, 400x850mm PNC 912580
- Fixed side shelf, 200x850mm PNC 912586
- Fixed side shelf, 300x850mm PNC 912587
- Fixed side shelf, 400x850mm PNC 912588
- Stainless steel front kicking strip, 800mm width PNC 912634
- Stainless steel side kicking strip left and right, wall mounted, 850mm width PNC 912659
- Stainless steel side kicking strip left and right, back-to-back, 1700mm width PNC 912662
- Stainless steel plinth, against wall, 800mm width PNC 912882
- Stainless steel side panel, 850x700mm, right side, against wall PNC 913003
- Stainless steel side panel, 850x700mm, left side, against wall PNC 913004
- Back panel, 800x700mm, for units with backsplash PNC 913013
- Endrail kit, flush-fitting, with backsplash, left PNC 913115
- Endrail kit, flush-fitting, with backsplash, right PNC 913116
- Scraper for smooth plates PNC 913119
- Endrail kit (12.5mm) for thermaline 85 units with backsplash, left PNC 913206
- Endrail kit (12.5mm) for thermaline 85 units with backsplash, right PNC 913207
- U-clamping rail for back-to-back installations with backsplash (to be ordered as S-code) PNC 913226
- Insert profile, d=850mm PNC 913231
- Perforated shelf for warming cabinets and cupboard bases (one-side operated TL80-85-90 and two-side operated for TL80) PNC 913234
- Energy optimizer kit 32A - factory fitted PNC 913247
- Side reinforced panel only in combination with side shelf, for against the wall installations, right PNC 913261
- Side reinforced panel only in combination with side shelf, for against the wall installations, left PNC 913262
- Shelf fixation for TL80-85-90 one-side operated, TL80 two-side operated PNC 913281
- Filter W=800mm PNC 913665
- Stainless steel dividing panel, 850x700mm, (it should only be used between Electrolux Professional thermaline Modular 85 and thermaline C85) PNC 913670

- Stainless steel side panel, 850x700mm, flush-fitting (it should only be used against the wall, against a niche and in between Electrolux Professional thermaline and ProThermetic appliances and external appliances - provided that these have at least the same dimensions) PNC 913686

Recommended Detergents

- C41 HI-TEMP RAPID DEGREASER, 1 pack of six 1 lt. bottles (trigger incl.) PNC 0S2292



Electrolux
PROFESSIONAL

**Modular Cooking Range Line
thermaline 85 - Electric Free-cooking Top
on Warming Cabinet with Backsplash H=700**

Front

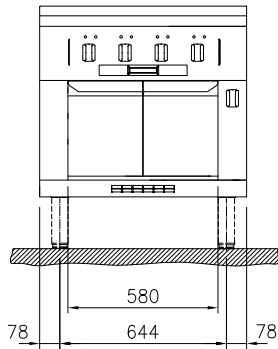

Side

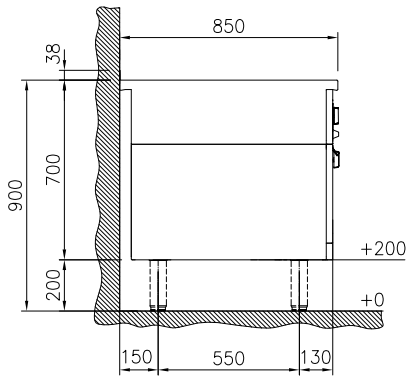

EI = Electrical inlet (power)
EQ = Equipotential screw

Top

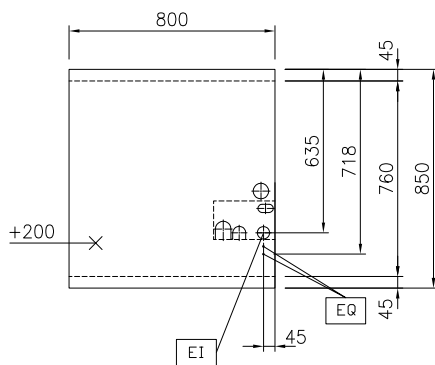

**Modular Cooking Range Line
thermaline 85 - Electric Free-cooking Top on Warming Cabinet with
Backsplash H=700**
The company reserves the right to make modifications to the products
without prior notice. All information correct at time of printing.

Electric

Supply voltage: 400 V/3N ph/50/60 Hz
Electrical power, max: 14.3 kW

Key Information:

Working Temperature MIN: 80 °C
Working Temperature MAX: 350 °C
External dimensions, Width: 800 mm
External dimensions, Depth: 850 mm
External dimensions, Height: 700 mm
Storage Cavity Dimensions (width):
Storage Cavity Dimensions (height):
Storage Cavity Dimensions (depth): 0 mm
Net weight: 149 kg
Configuration: On Oven; One-Side Operated
Front Plates Power: 3 - 3 kW
Back Plates Power: 3 - 3 kW
Solid top usable surface (width): 670 mm
Solid top usable surface (depth): 650 mm

Sustainability

Current consumption: 30.5 Amps